

MANUFACTURERS AND CONTRACTORS

Phone 716-941-6141

Fax 716-941-3828

1-800-421-6141

LIGHTNING PREVENTOR OF AMERICA

DIVISION OF HEARY BROS. LIGHTNING PROTECTION CO., INC.

Lightning Protection Systems

11291 Moore Road
Springville, New York 14141

**THE MOST ECONOMICAL
LIGHTNING PROTECTION
IN THE WORLD**

Guaranteed
Insured



Lightning

PREVENTOR



Preventor

**Lightning Protection
with a Guarantee:
Your System's Performance
is Insured.**



LIGHTNING AIR TERMINAL
SYSTEM PREVENTOR 2005.

TYPICALLY PROVIDES THE
MOST ECONOMICAL METHOD
OF LIGHTNING PROTECTION IN
EXISTENCE. THE COST OF THIS
TYPE OF SYSTEM PROTECTION IS
CONSIDERABLY LESS THAN THE
COST OF THE FARADAY/MULTIPOINT
CONVENTIONAL SYSTEM.

- THOUSANDS OF INSTALLATIONS
WORLDWIDE
- INSURED
- GUARANTEED
- INSTALLATION INSPECTIONS
AVAILABLE BY APPLIED RESEARCH
LABORATORIES, INC. FOR
COMPLIANCE WITH INSTRUCTIONS
OF HBP-21 MANUFACTURER'S
STANDARD
- COMPONENTS LISTED BY UL AND
APPLIED RESEARCH
LABORATORIES, INC.

PREVENTOR: FIGURE 1

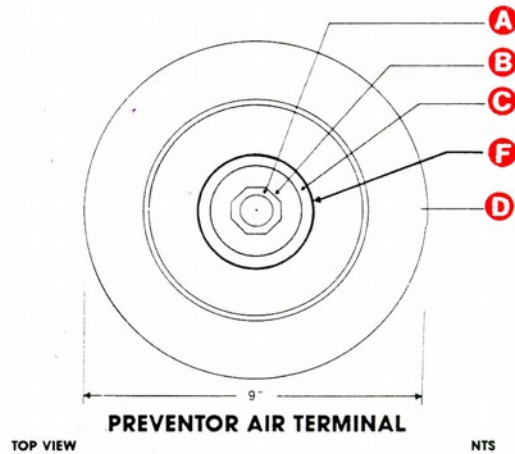

Notes:

- A** Air terminal $\frac{5}{8}$ " copper material HD 29 CU heavy chrome plated 24 CH.
- B** Lock nut copper material HD. Chrome plated.
- C** Washer copper material HD. Chrome plated.
- D** Support structure material of soft copper. Chrome plated.
- E** Preventor air terminal screws into top of pole mast.
- F** Sphere—threaded to air terminal.

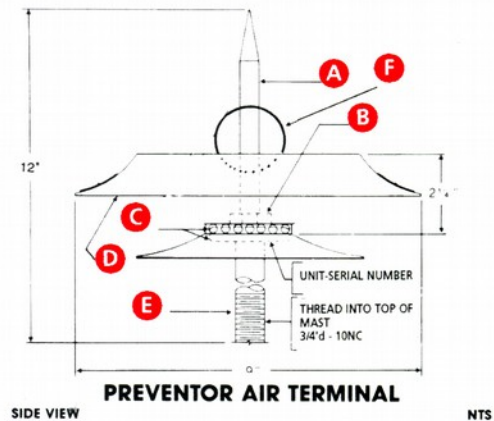

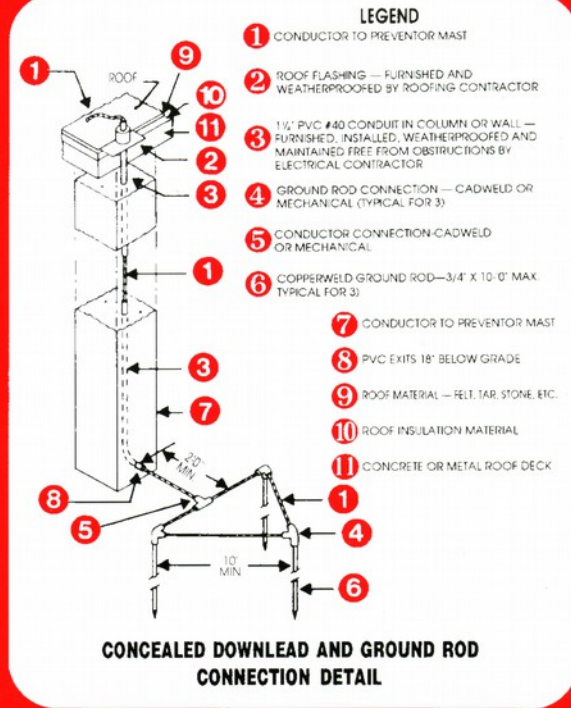
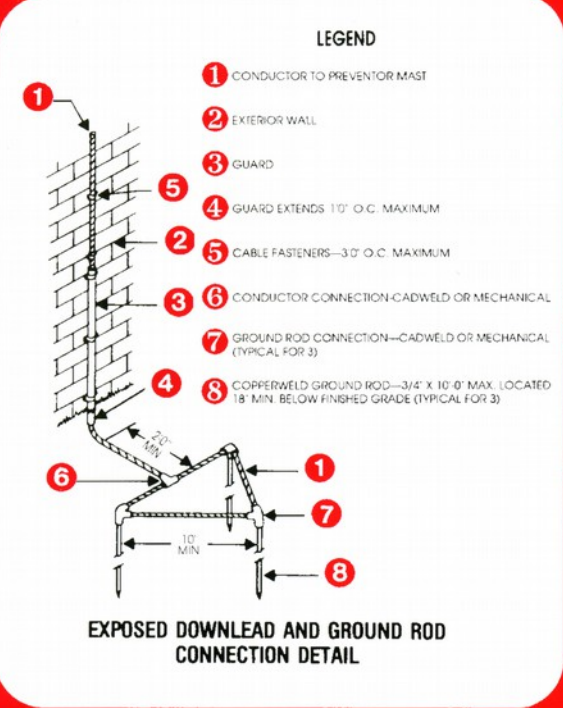
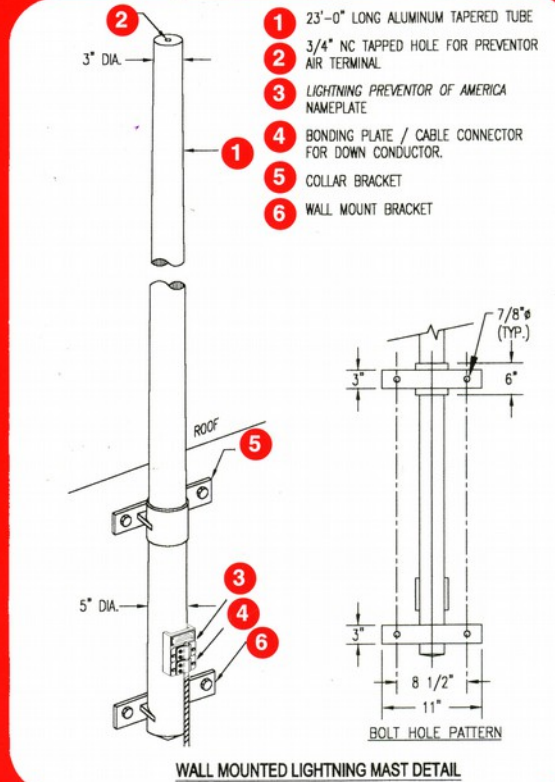
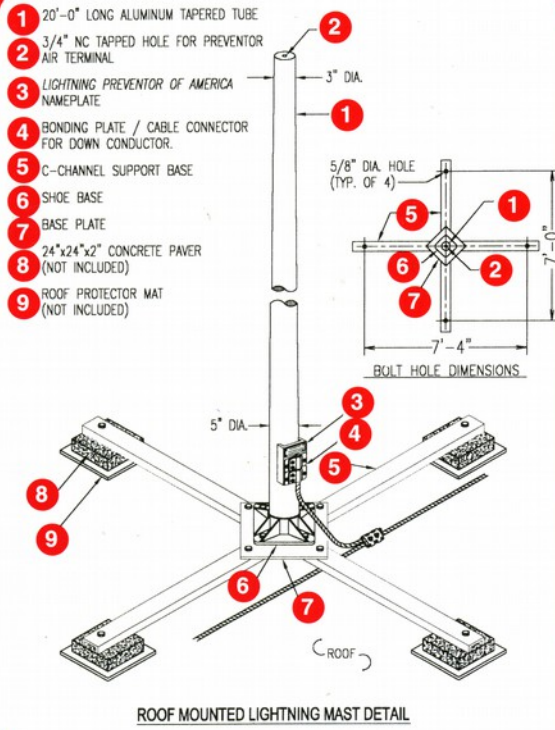

LIGHTNING PROTECTION MECHANISM

Lightning can be defined as “a rapid exchange of electrical charges between the cloud and the ground,” depending on whether the base of the cloud is positive or negative, and on whether the lightning bolt comes from the cloud, or the ground.

Lightning bolts can be classified in four categories: negative descending, negative ascending, positive descending and positive ascending. The fact is that “positive ascending” lightning bolts are by far the most frequent: 90% if we take an average of the figures given by 16 specialists in different countries. We shall describe the mechanism of this type of discharge below.

When the potential gradient at the base of the cloud reaches a sufficient value (about 10K/cm), a jet of ion electrons is projected earthward and produces a luminous

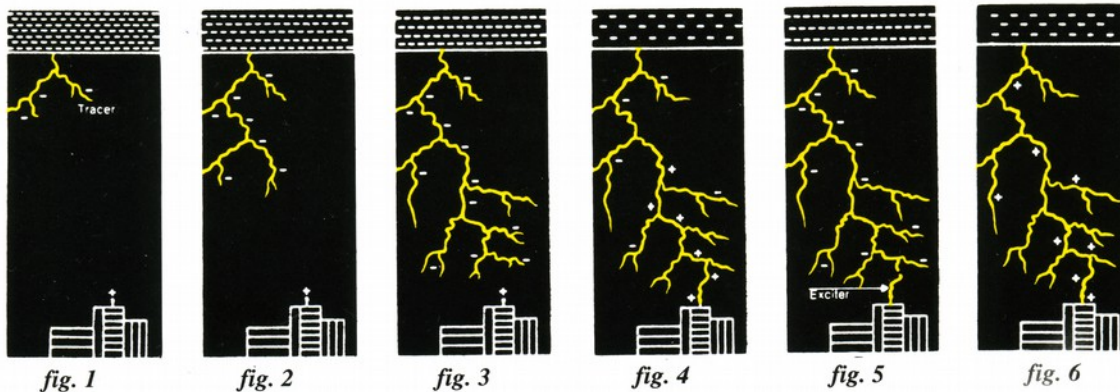

track in the sky. Depending on the author, this discharge is called a lightning bolt, tracer, arrow or pilot discharge (figure 1).

Any cause whose effect is to concentrate ion electric charges on the earth’s surface, or near it, reinforces the local ion electric field and tends to divert the downward ion leader tracer towards the nearest ion concentration point of impact. The downward ion “tracer” covers 30 to 50 meters at speed ranging from 60 to 50,000 km/s (figure 2). After a pause of 30 to 100us, a second downward ion “tracer” follows the path taken by the first downward ion “tracer,” extending it by about 50 meters (figure 3). A third downward ion “tracer” is released, then a fourth and so on, with the end of the downward ion “tracer” always getting closer to the earth (figures 4,5,6).

The ion electric field increases progressively between the downward ion leader tracer and the earth, and when it reaches a sufficient level, an upward positive streamer ascending jet leaves a point on the earth and joins the downward ion “tracer” from the cloud. The upward ascending ion positive streamer jet can be as long as 150 meters. An intense ionized current then passes through the conducting channel thus produced. This is the main lightning discharge, which can be followed by a series of secondary lightning discharges, all taking, not stepwise, but in a single stroke, the path ionized by the main discharge. This happens with any projecting conducting structures on the earth’s surface, such as lightning protection system air terminals, satellite dishes, radio and television antennas.

Research by Dauzers (at the time Director of the Earth Physics Laboratory of the Pic du Midi) in 1928, and confirmed in the Soviet Union by Bogoiavlenski and Chatelain, showed that the favorite lightning strike impact points on the earth are places where the air has maximum conductivity due to a high concentration of ionization on the earth’s surface.

These areas include outcroppings of metal ore, such as granite rocks, ferruginous clays and limestones through which underground water flows and generally contain radioactive compounds.

The tropical regions of the earth contain the most areas vulnerable to lightning, although other latitudes are not immune. In the United States there are many tragic losses of life each year and there are large sums of monies expended

in repairs to structures damaged by lightning.

From the beginning of time man has sought to protect himself, his family and his property against the ravages and devastating effects of lightning.

During the course of the last 20 years, damage caused by lightning has increased greatly as the result of considerable urban expansion. Cities are continually sprawling outward into the countryside and shooting upward, in the form of taller buildings. As long as this expansion continues, damage due to lightning will continue to rise. It would be folly not to take precautions against lightning, especially now that full protection can be provided at a very reasonable cost.

FRANKLIN CONE

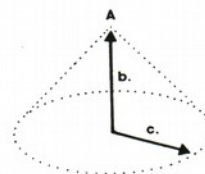

In a Franklin Lightning Protection System, the air terminal protects the volume of a cone in which the radius of the base is equal to the height of the air terminal. This method is satisfactory for church spires, tall industrial chimneys and towers in which the zones to be defended are contained within the cone. Where this method can be usefully employed, the cost of installation is reasonable and nearly always justifiable.

FARADAY CAGE

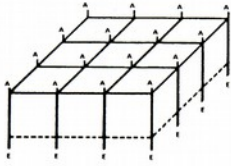

In a Faraday Cage System, the lightning protection is comprised of multiple air terminals, not less than one foot high, fixed on all salient points on the roof and bonded together with roof conductors and down conductors to form a cage not greater than

50 feet x 150 feet and with air terminals at the intersections of center roof areas. This method is not totally satisfactory because it leaves the areas in the center of the roof between the conductors unprotected, unless these areas are defended by air terminals or roof conductors at higher levels.

The building illustrated is 150 ft. x 150 ft. x 100 ft. high. The efficiency of this method is lower than that of the Franklin method because any point discharge current available is divided at random between the multiple air terminals, whereas it would be more if it would be concentrated at one salient air terminal, as in the Franklin method. The Faraday method is very expensive and particularly so when we consider the large expanse of roof area which remains undefended.

It is only rarely that the cost can be considered to be justifiable.

IONIZING LIGHTNING CONDUCTORS

The inspiration of these devices springs from J.B. Szillard, a colleague of Madame Curie. A paper "Sur un paratonnerre au Radium" was read by him to the Academy of Sciences in Paris on 9th March, 1914.

The first ionizing lightning conductor was patented by Gustav P. Capart, also a colleague of Madame Curie, in 1931.

In 1953 Alphonse Capart, the son of Gustav, improved on his father's device, the final result is known as PREVENTOR.

Preventor

(1) PREVENTORS are dynamic in operation, whereas the former methods are static. For example, when a storm cloud approaches a protected building, the electric ion field between the cloud and ground is increased. The ions constantly flowing from the unit, carry some of the ground ion charges towards the cloud and this has the effect of temporarily lowering the intensity of the ion field between cloud and ground.

It must be clearly understood that it cannot neutralize a cloud. It does no more than reduce the tension for the small time during which the cloud is passing overhead - but this temporary lowering of the tensions is

SOMETIMES SUFFICIENT TO PREVENT A LIGHTNING DISCHARGE FROM TRIGGERING OFF — on the other hand, when this lowering of tension is inadequate to prevent triggering, a conductive ion streamer is provided as described.



(2) PREVENTORS: Installation pursuant to HBP-21 Manufacturer's Standard calls for fewer terminals - often a single terminal - typically resulting in substantial cost savings.

(3) PREVENTOR system also is fully guaranteed with the added feature of over \$10,000,000 insurance coverage when installed in compliance with HBP-21 (levels 1 & 2).

(4) PREVENTOR SYSTEMS: Thousands of Preventor installations worldwide.

(5) INSPECTIONS OF INSTALLATIONS: For compliance with HBP-21 Manufacturer's Standard available from Applied Research Laboratories, Inc.

(6) PREVENTORS can be fitted to an EXISTING INSTALLATION to increase the efficiency and provide greater protection, provided that the existing down conductor and earth termination conform to Manufacturer's Standard for Lightning Protection Systems.

(7) PREVENTORS require only one down conductor and earth terminal per Preventor and, in consequence of this, there exists one definite salient air terminal to which a lightning discharge can be directed because it is vastly superior to other nearby salient points.

(8) The single air terminal, down conductor and earth terminal require very little maintenance.

QUESTIONS AND ANSWERS

Q. What is the life of a PREVENTOR?

A. Longer than any structure on which it can be fitted.



Q. What are the effects of corrosion in normal atmospheric conditions?

A. The spike is chromium plated copper. The head is special chromium plated copper.

Q. How often do the heads need to be replaced?

A. Not less than 100 years (accidents excepted).

Q. How can small quantities of ionizing substances influence these fields of high intensity?

A. Lightning discharges take the paths of least resistance and the forces of nature are most precise in the establishment of this path. These forces establish not only which particular brick on the chimney shall be the target for lightning but further they dictate from which square millimeter on that brick the ground streamer shall be initiated since it is a "point discharge."

LIGHTNING PREVENTOR MOUNTING DETAIL

PREVENTOR AIR TERMINAL

LIGHTNING PROTECTION SYSTEM SPECIFICATIONS

1) Furnish and install all labor, equipment and materials in performing all operations as noted herein in connection with the installation during construction of a Preventor Lightning Protection System to be installed during construction of a structure. All cables which run from roof to ground shall be run in 1-1/4" P.V.C. conduit, furnished and installed by the Electrical Contractor, in the walls and as indicated on lightning protection drawings previously submitted and approved.

2) The shop drawing would indicate the extent and general arrangement of the lightning protection system, showing the location of the grounds, cable coursing, and where to locate the Preventor Air Terminal. The Electrical Subcontractor shall furnish and install all required items and accessories to have the system approved by a competent authority.

3) Proper roof flashing shall be supplied by the roofing contractor and installed by the roofing contractor.

4) Conductors on structures under 100 feet in height shall consist of copper ropelay cable composed of 28 strands of 14 gauge wire weighing not less than 375 pounds per 1,000 feet. Conductors on structures over 100 feet in height shall consist of copper cable composed of 28 strands of 13 gauge wire weighing not less than 420 pounds per 1,000 feet.

5) Air terminal shall be a Preventor as manufactured by Lightning Preventor of America, Division of Heary Bros. Lightning Protection Co., Inc., No. LPA-2005; no substitutes will be accepted. Air terminal shall be designed specially for Preventor air terminals as manufactured by Lightning Preventor of America, Division of Heary Bros. Lightning Protection Co., Inc., of Springville, New York, 14141.

6) Cable on flat roof area may be run exposed. Cable fasteners on the flat roof shall be of the adhesive type spaced every 3'-0" on conductors.

7) Downlead cables to ground shall terminate in a triangular ground grid of three 3/4" x 10 ft. copperweld ground rods. LPA-107, installed a minimum of 2 feet below finished grade. Connections to ground rods shall be LPA-57D, Bolt pressure clamp. One such downlead shall be bonded to the water service line. Mechanical connectors are acceptable.

8) Excavating, back filling and tamping of earth around ground grids and rods shall be furnished and completed by the General Contractor.

9) Shop drawing shall be provided for the architect and engineer or owner by the Lightning Protection Contractor and be approved before installation begins.

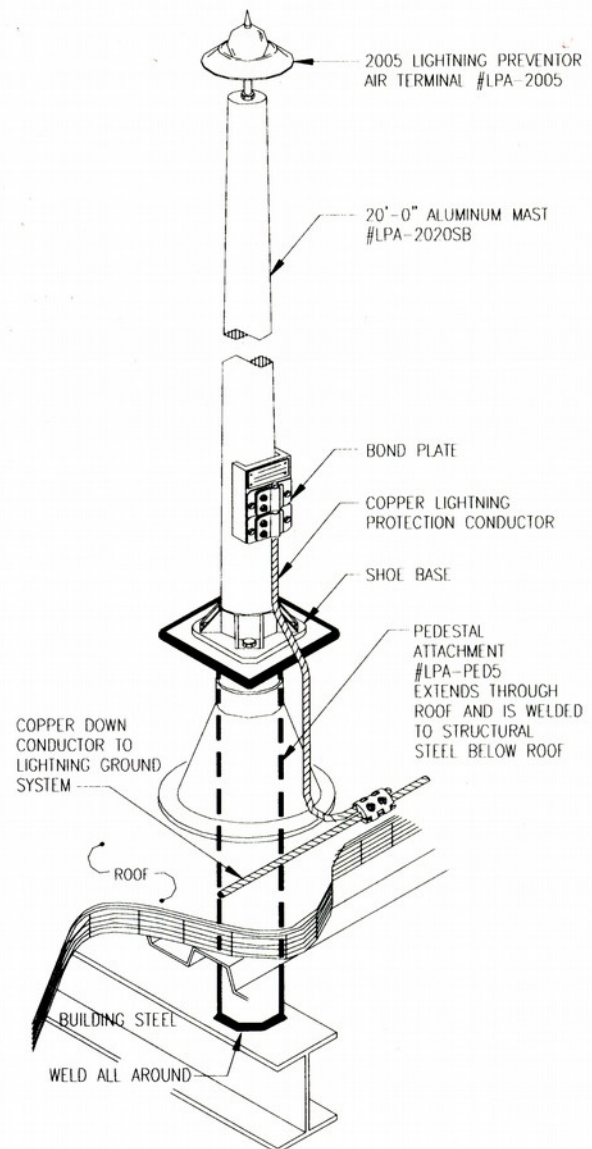

Preventor: Lightning Protection with a Guarantee

Guarantee

LIGHTNING PREVENTOR OF AMERICA, DIVISION OF HEARY BROS. LIGHTNING PROTECTION CO., INC. HEREBY GUARANTEES that this Preventor will provide lightning protection for system design complying with the Manufacturer's Standard (HBP-21, Levels 1&2) and will maintain this protection for more than 100 years, for the original owner only of the facility on which the system is installed, provided that the Preventor is properly installed, annually inspected, and so maintained and that the earth resistance test is preserved at less than 10 ohms of earth resistance of all structures within the defended area. Steel base being acceptable. This Guarantee is limited to the structural building only and also excludes surge transient protection for services.

Certificate of Guarantee

Lightning Preventor of America
Division of Heary Bros. Lightning Protection Co., Inc.
hereby certifies

CATASTROPHE UMBRELLA POLICY

THE CATASTROPHE UMBRELLA POLICY GUARANTEES THE
PREVENTOR LIGHTNING PROTECTION SYSTEM
WITH A PRODUCT INSURANCE POLICY OF \$10,000,000.00.

